

# CRAB

Oil slicks optical detector

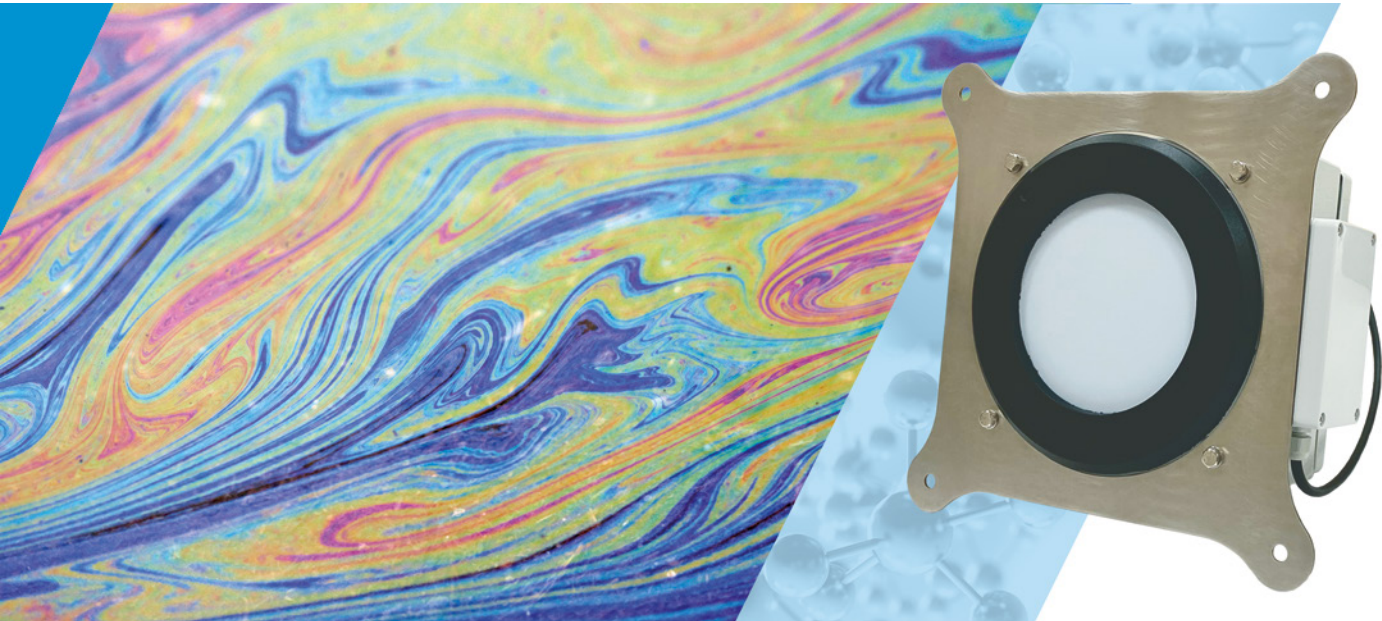

CRAB is an easy-to-operate oil slicks optical detector. The instrument detects the presence of oil films on the water surface using optical sensing with a vertical laser beam. The difference in the reflective properties of water and oil enables to detect oil films. CRAB sensor detects any type of oil regardless of its nature, physical characteristics, and chemical content.

## FEATURES AND ADVANTAGES

- Continuous remote optical sensing, no sampling
- High sensitivity: detection of oil slicks with thickness down to 0.5 micron
- Sensitive to oils of any nature (mineral, synthetic, or vegetable)
- No interference from scattered radiation
- Low interference from ripples and waves (beam/ surface angle up to  $\pm 20^\circ$ )
- Waterproof housing for outdoor installation
- Optional heating of the sensor is available upon request
- Mounting at stationary points, buoys, motor boats
- Accuracy of detection irrespective of mounting height
- Long-term operation without maintenance

## APPLICATIONS

- Monitoring of water surfaces (sea, harbors, lakes, rivers)
- Oil leakage detection
- Monitoring of process and waste waters

## SPECIFICATIONS

Detecting object	Oil slick on water surface
Min detectable oil film thickness	0.5 $\mu\text{m}$
Waviness of water surface (RMS wave slope)	up to 20 °
Mode of measurement	Continuous
Response time	not more than 10 s
Communication ports	RS-485 Current loop 4–20 mA
Data transfer protocols	Modbus RTU Analogue 4–20 mA
Power supply	100–240 VAC, 50–60 Hz 12 VDC Power supply cable length: up to 200 m (100 m in case of heated sensor option)
Power consumption	up to 15 W
Ambient conditions	Temperature: -0 to +50 °C -20 to +50 °C (optional) Humidity: up to 100% (rain)
Distance to the water surface	0.5–10 m
Dimensions	not more than 200×300×146 mm
Weight	up to 3.5 kg

## EQUIPMENT AND OPTIONS

- CRAB optical detector
- Power supply unit for AC 100–240 V power mains (optional)

## WARRANTY

CRAB optical detectors are covered by a full 1-year warranty.

## SERVICE

Installation and commissioning of Lumex Instruments' CRAB detectors can be carried out at a customer site by our service engineers or by certified distributor service engineers.

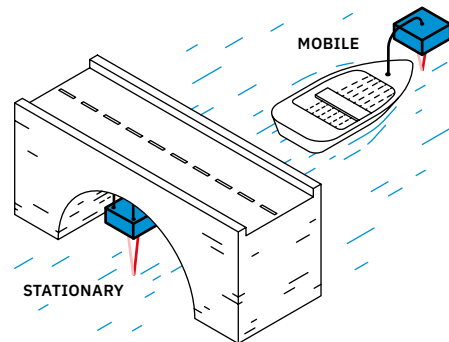

Installation options for CRAB oil slick optical detector



Find your local Lumex Instruments distributor:  
[www.lumexinstruments.com](http://www.lumexinstruments.com) | [sales@lumexinstruments.com](mailto:sales@lumexinstruments.com)